

1400 - FLOWMATE

OPERATION INSTRUCTIONS

VERSION 1.1

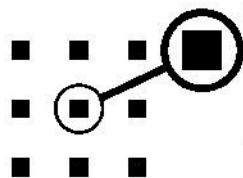

FARMSCAN

PART No: AM – 1400/2

TABLE OF CONTENTS

1.0	COMPONENT LIST.....	3
1.1	<u>COMMON PARTS.....</u>	3
2.0	GENERAL INFORMATION.....	4
3.0	INSTALLATION.....	4
3.1	<u>OVERHEAD INSTALLATION.....</u>	5
3.2	<u>SUCTION PROBE INSTALLATION.....</u>	5
4.0	OPERATION.....	6
4.1	<u>ON/OFF KEY.....</u>	6
4.2	<u>TOTAL KEY.....</u>	6
4.3	<u>BATCH KEY.....</u>	7
4.4	<u>RATE KEY.....</u>	7
5.0	CALIBRATION.....	8
5.1	<u>CALIBRATION WARNING.....</u>	8
5.2	<u>MANUAL CALIBRATION PROCEDURE.....</u>	8
5.3	<u>TEST BATCH CALIBRATION.....</u>	9
5.4	<u>TEST BATCH PROCEDURE.....</u>	9
6.0	BATTERY RECHARGING.....	11
7.0	MAINTENANCE.....	11
8.0	TROUBLESHOOTING.....	12
9.0	TURBINE ASSEMBLY.....	13
10	TECHNICAL SPECIFICATIONS.....	13
11	CALIBRATION REFERENCE CHART.....	14

1.0 Component List

1.1 Common Parts

1400 FLOWMATE KIT

REF	PART No.	DESCRIPTION	QTY
1	A-1400 / 2	FLOWMATE UNIT	1
2	HH-1100	1" BSP POLY NIPPLES	2
3	AC-500	D.C. RECHARGE CABLE	1
4	AH-480	CLEAR KEYPAD MEMBRANE	1
5	AH-200	TURBINE SERVICE TOOL	1
6	AM-1400 / 2	1400 FLOWMATE MANUAL	1
7	AM-200	WARRANTY REGISTRATION CARD	1

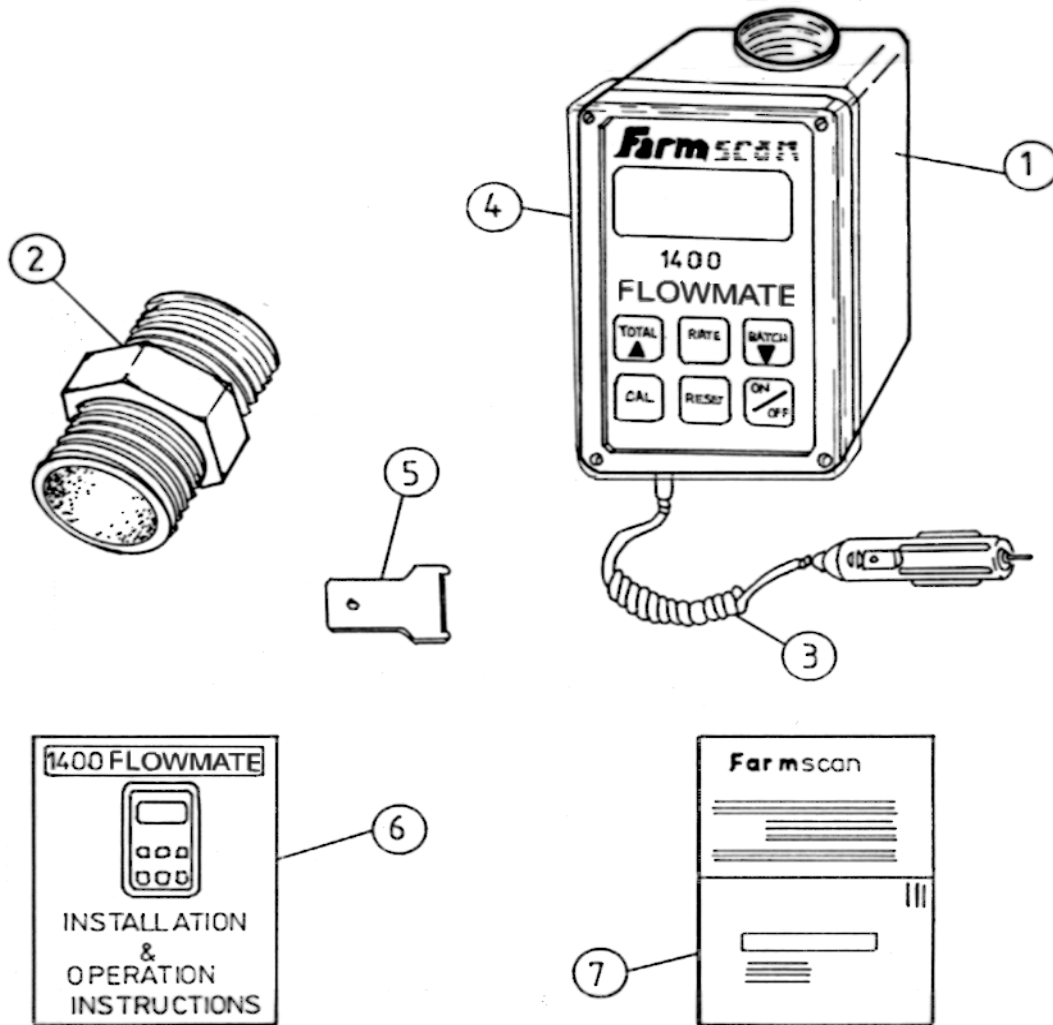

2.0 General Information

The 1400 Flowmate gives both an overall TOTAL of volume used and a resettable BATCH total for each operation. The flowrate (L/MIN or G/MIN) can be displayed whilst liquid is flowing.

Both the TOTAL AND BATCH readings can be reset or left to accumulate so you can reset the BATCH reading after each operation and keep the TOTAL readings for future reference.

Metering of Water, Petrol, Diesoline and solvent based materials including most Agricultural Chemicals is possible. The meter is not suitable for acids such as defoliants.

Engraved on the underside of each meter is a factory calibration factor, which is accurate for water at around 20 degrees Celsius. This calibration factor is the number of pulses per litre generated by your particular meter. (eg PPL 113.3)

Multiply calibration factor by **3.785** to read US gallons or by **4.546** to read IMP gallons.

If measuring water, or any other material with the same Viscosity as water, this factor can be entered into any of the three calibration memories of the Flowmate.

When measuring liquids with a higher or lower viscosity than water, you need to establish a new calibration factor as explained in the Calibration section.

NOTE: In very cold conditions, the display digits may appear to change slowly, but this will not affect the accuracy of the meter.

3.0 Installation

Install the Flowmate in line with the direction of flow as shown by the arrow on the body. Do not install the meter directly onto a vibrating pump.

The meter will work accurately on gravity feed, suction or pressure side of a pump providing the minimum flow rate of 8 LPM (2.11 US GPM) is achieved.

Be sure to use the 1" inlet and outlet nipples supplied when installing the meter to avoid the possibility of damage caused by over length threads inserted into the meter.

The 1400 Flowmate is sealed against splashing of liquids, but not total immersion.

3.1 Overhead Installation

Fit a ball or gate valve at Flowmate INLET to enable removal of the meter for recharging and turbine inspection.

Protect the meter from constant weathering when not in use.

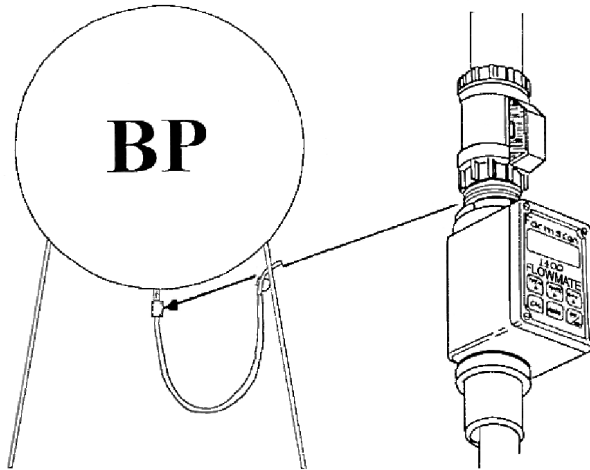

3.2 Suction Probe Installation

Fit the Flowmate at the top of the suction probe as shown with a ball valve installed just before the meter to enable controlled measuring of small quantities. It is recommended to use Camlock Fittings IN and OUT of the meter to enable easy removal for recharging, storage and turbine inspection.

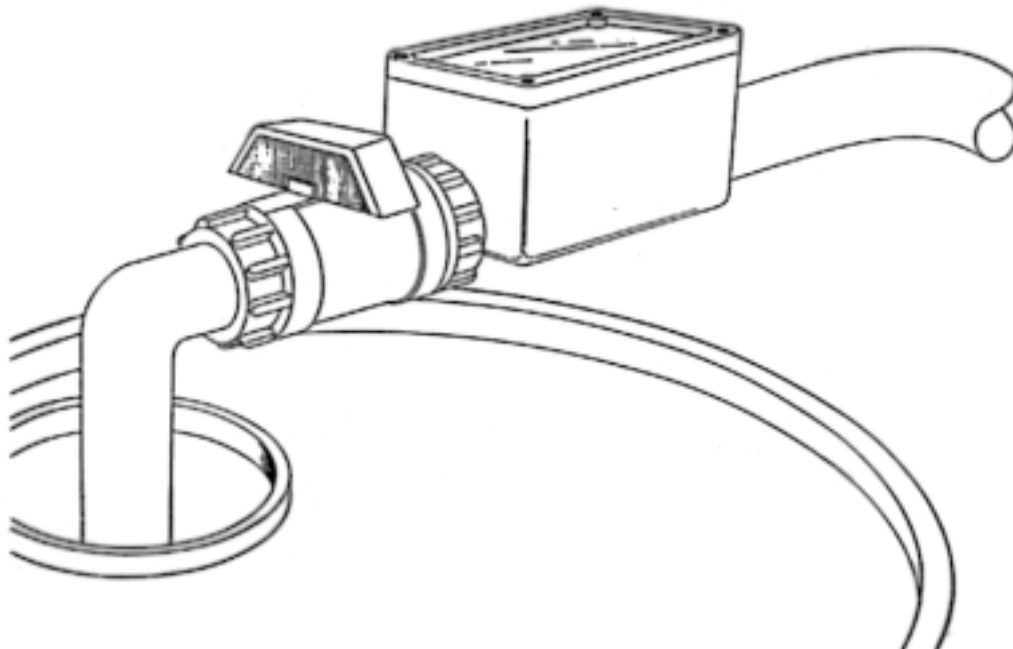

4.0 Operation

4.1 ON/OFF Key:

When you press the ON/OFF key the readout will momentarily display whichever of the three calibration memories is engaged.

EG. OR OR

Then immediately display the current TOTAL litres (or gallons) in memory.

EG.

When you turn the meter OFF, all totals and calibration settings will remain in memory.

If the meter is not used for 30 minutes the display will shutdown to reduce power consumption. The display will re activate immediately flow commences or when a key (other than the ON/OFF key) is pressed.

Turn the meter OFF when not in use to conserve the batteries.

The readout will FLASH when batteries need recharging.

4.2 Total Key

Press the TOTAL key to display the current accumulated total litres (or gallons).

The readout features a floating decimal point to allow the following resolution.

0 - 999.9	Tenths of a Litre (or gallon)
1000 - 9,999,999	Whole Litres (or gallons)

Because the readout is limited to four digits, above 9999 litres (or gallons) the total will be displayed in two consecutive screens with a one (1) second interval.

eg. 19,864 litres would appear firstly as:

Then:

To zero the TOTAL, first press TOTAL, then hold down the RESET key for approximately two seconds until display clears.

4.3 Batch Key

Press the BATCH key to display a separate accumulated litre total, similar to a car trip meter. You can zero the BATCH total independently of the overall TOTAL. Display resolution is the same as total litres.

To zero the Batch total, first press BATCH, then hold down the RESET key for approximately two seconds until display clears.

4.4 Rate Key

Press the RATE key at any time liquid is flowing to display instantaneous flow rate in Litres per Minute or Gallons per Minute.

5.0 Calibration

The Flowmate requires a correct calibration factor to be entered into one of 3 calibration memories before operation.

The calibration factor refers to the number of electrical pulses per litre (PPL) generated by the turbine impeller.

The PPL calibration factor will be smaller for higher viscosity materials.

Calibration factors may also vary with different installations.

Engraved into the underside of each meter is a factory tested reference calibration factor for water. eg. PPL 113.3.

To read US gallons multiply engraved PPL factor by 3.785
To read IMP gallons multiply engraved PPL factor by 4.546

This factor may be entered if measuring water, but should be verified by metering a known quantity of liquid.

The TEST BATCH CALIBRATION PROCEDURE should be used to establish a new calibration factor (PPL) for other liquids of various viscosities.

Once you know a new factor, it can be manually entered at any time using the MANUAL CALIBRATION PROCEDURE, so write it down for future reference.

5.1 Calibration Warning

If calibration factors are corrupted, the readout will display HELP to indicate the calibration factors must be re entered.

eg.

5.2 Manual Calibration Procedure:

1. Press CAL key in succession to choose one of three memory locations H1, H2 or H3. After each key press, the current calibration factor for that memory will be displayed.

eg.

H1	⇒	113.3
H2	⇒	101.7
H3	⇒	125.4

2. To engage one of the three calibration factors displayed, press RATE key after the required factor is displayed.

To alter a calibration factor, use UP or DOWN key first, then press RATE key to engage.

3. Turn meter OFF then ON again to check that the correct calibration memory is engaged. (see OPERATION ON/OFF KEY)

5.3 Test Batch Calibration:

This procedure involves pumping or sucking an exact known quantity of liquid through the meter. The Flowmate will count the total number of pulses generated then display the new calibration factor.

If sucking liquid through the meter use a calibrated bucket and fill to 20 litres or 5 gallons, start with the probe submerged and suck 15 litres or 4 gallons out to avoid errors caused by sucking Air at the finish.

When pumping liquid, pre prime the meter to avoid counting errors at start of test. Any type of tap installed downstream of the meter will help.

The test must be done with the meter fully installed and at the normal flowrate for best results.

Note: Test batch quantities of 10 litres (2 gallons) or greater are preferred. Maximum test batch is 999 litres (or 999 gallons).

5.4 Test Batch Procedure:

1. Fully prime meter with liquid.
2. Turn meter ON and press CAL key to select any memory location. (H1, H2 or H3).

eg.

3. Press RESET key to display the default test batch quantity of 20 litres (or gallons)

eg. LITRES

4. Use the UP or DOWN keys to alter the test batch quantity if desired.

eg. LITRES

5. Press RESET key to accept test quantity and the display will zero.

eg.

6. Now pump or suck the test quantity through the meter and shut off flow at the correct point. The total pulses counted will be displayed.

eg.

7. Press RESET to display the new calibration factor, which should be recorded for future reference.

eg. PPL

8. Press RATE key to engage new calibration factor.

6.0 Battery Recharging

The Flowmate has inbuilt rechargeable Nickel Cadmium batteries, which can be charged via a normal 12 volt D.C. cigarette lighter socket.

When fully charged, the batteries will provide at least 500 HRS continuous use.

The Flowmate display will flash when the batteries are running low.

NOTE: DO NOT press CAL when display is flashing, otherwise Calibration Factors may be lost from memory.

To recharge the batteries, connect the charging cable and leave Flowmate OFF overnight to recharge the batteries. The green charge cable light will be on to indicate power from the cigarette lighter socket is active.

If batteries are totally flat, full recharge will take 24 hours. Flowmate may be operated whilst on recharge if necessary.

WARNING: The rechargeable batteries are not user serviceable. Do not remove the facia bezel screws as this will damage the seal and void the warranty.

Extending Battery life: The life of Rechargeable Batteries will be severely reduced by the practice of daily recharging. Best practice is to wait till the display starts flashing before recharge.

! CAUTION!

FLOWSENSOR MUST BE THOROUGHLY DECONTAMINATED BEFORE PERFORMING ANY MAINTENANCE OF WETTED PARTS.

7.0 Maintenance

1. Check INLET strainer for build up of debris, which may cause inaccurate readings.
2. Flush Flowmate with fresh water immediately after use.
3. Clean impeller magnets as explained in TROUBLESHOOTING if operation becomes erratic.
4. Recharge the batteries every three months if not using the meter regularly.

8.0 Troubleshooting

PROBLEM	POSSIBLE CAUSE / REMEDY
1. WON'T SWITCH 'ON'	<ul style="list-style-type: none"> a) Recharge batteries for 5 Min to regain basic battery operation. b) Make sure Green light on charger cable is ON when charging c) If no response from Meter, return Flowmate & Recharge cable, to you're nearest Farmscan dealer or authorised service agent.
2. COUNTING INCORRECTLY OR READING WHEN NO FLOW	<ul style="list-style-type: none"> a) Recalibrate meter as explained using TEST BATCH PROCEDURE. b) If meter is subject to intense motor vibration, isolate meter from vibration with rubber hosing. c) If pump hammers, then fix pump or fit a suitable pulsation dampener. d) Keep meter away from petrol engine ignition wiring. e) Is Air being sucked through turbine? f) Follow Troubleshooting (3) to check impeller is not binding.
3. METER WON'T COUNT	<ul style="list-style-type: none"> a) Make sure the Calibration memory is not at zero b) Remove meter and thoroughly decontaminate, if used with chemicals. c) Blow softly into INLET without mouth contact, impellor should spin freely. d) Disassemble turbine as shown and inspect impeller magnets for particle build up that will weaken the magnetic strength. e) Clean impeller magnets with toothbrush and soapy water then reassemble turbine taking note of flow direction. f) Firmly tighten turbine retaining rings and blow softly into INLET to check impeller spins freely. g) If Turbine damaged, install complete turbine replacement kit. Order Part No. AH-202 Black Turbine Kit. h) Unable to rectify fault, return to nearest Farmscan dealer or authorised service agent.

PROBLEM	POSSIBLE CAUSE / REMEDY
4. GREEN LIGHT ON CHARGER CABLE FAILS	a) Make sure vehicle ignition key is ON. b) Plug cable into a different vehicle to check if cigarette lighter socket is faulty. c) Remove knurled fitting at cigarette lighter end of charge cable and replace fuse with MAXIMUM 3AMP 3AG fuse. d) Replace faulty charge cable.

9.0 Turbine Assembly

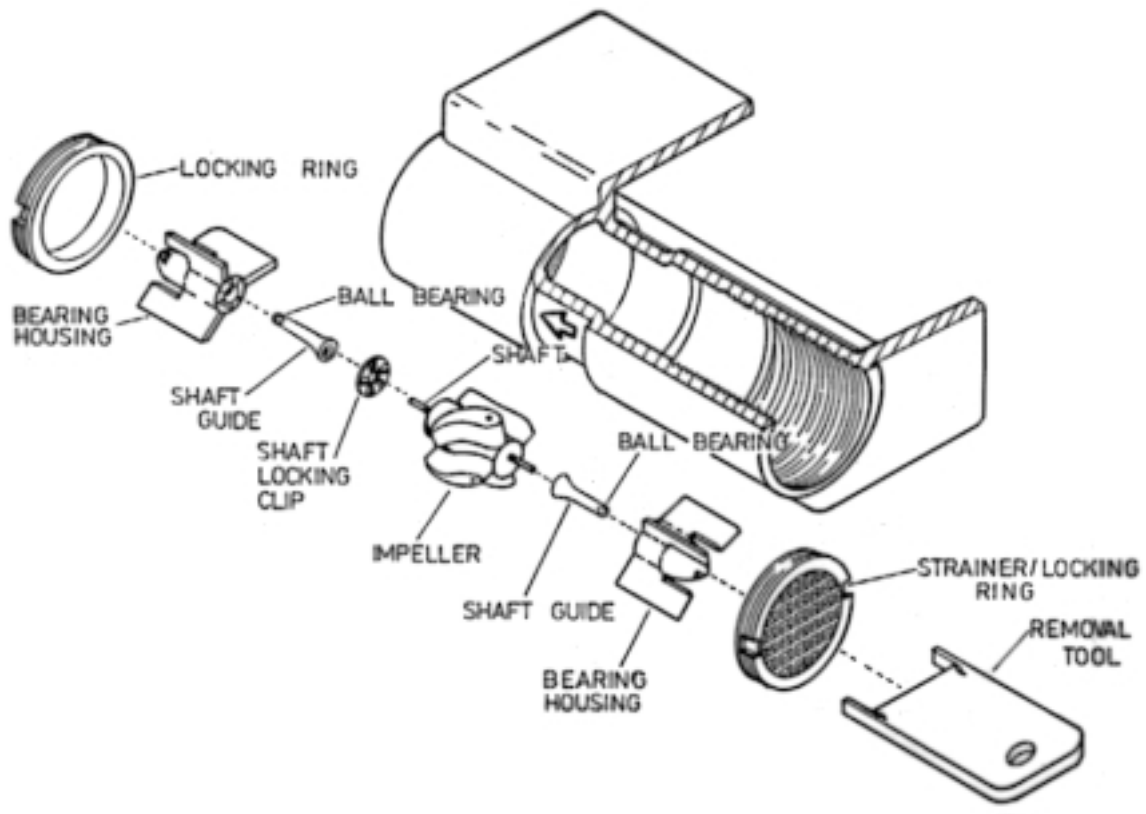

10 Technical Specifications

Flow Range: 8 – 200 litres per minute (2.1 – 52.8 US gallons per minute)
 Thread: 1" BSP female thread
 Accuracy: +/- 1% field calibration
 Operating Temperature: 5 – 50 °C (41 – 122 °F)
 Maximum Pressure: 1000 kPa (145 psi)

