

rate controller 1560

rate controller **1560**

Installation and Operation
Instructions

Contents

PARTS LIST	2
OPTIONAL CABLES	2
PARTS PICTORIAL - 1560 RATE CONTROLLER.....	3
1.0 INSTALLATION.....	4
1.1 POWER CONNECTION	4
1.2 SENSOR & WIRING INSTALLATION.....	5
1.3 FLOW SENSOR INSTALLATION.....	6
1.4 WHEEL SENSOR INSTALLATION	7
CALIBRATION	8
2.1 WHEEL FACTOR CALCULATION	9
2.2 FLOWSENSOR FACTOR CALCULATION.....	10
2.3 ENTERING CALIBRATION FACTORS.....	11
3.0 OPERATION	13
3.1 POWER ON / OFF KEY	13
3.2 SPEED KEY	13
3.3 AREA KEY.....	13
3.4 RATE KEY	13
3.5 RESET KEY.....	13
3.6 MEMORY BACKUP	13
3.7 RUN HOLD FUNCTION	14
4.0 TROUBLESHOOTING 1560 RATE CONTROLLER.....	15
5.0 INTERFERENCE CAUSES AND REMEDIES.....	18

PARTS LIST

REF	PART NO.	DESCRIPTION	QTY
1	A-1560	RATE CONTROLLER	1
2	A-1560P	RATE CONTROLLER POD	1
3	AA-117	SHAFT MAGNET - CLAMP	1
4	AC-110P	REED TYPE SENSOR	1
5	AC-1560CP	1560 TO POD LOOM	1
6	AC-1560FC	1560 POD FLOW/CONTROL LOOM	1
7	AH-504	BRACKET	1
8	AH-504MP	BRACKET MOUNTING PLATE	1
9	HS-1/412	SET SCREW	2
10	HS-10X3/4SS	SELF TAPPER	2
11	HW-1/4S	STAR WASHER	2
12	HG-706	CABLE TIES	10
13	AM-1560	RATE CONTROLLER MANUAL	1
14	AM-200	WARRANTY CARD	1
15	AA-125	FLOW SENSOR (1-18LPM)	1

OPTIONAL CABLES

PART NO.	DESCRIPTION OF KIT
AC-205	5m 2 WAY EXTENSION CABLE
AC-305	5m 3 WAY EXTENSION CABLE
AC-210	10m 2 WAY EXTENSION CABLE
AC-310	10m 3 WAY EXTENSION CABLE

PARTS PICTORIAL - 1560 RATE CONTROLLER

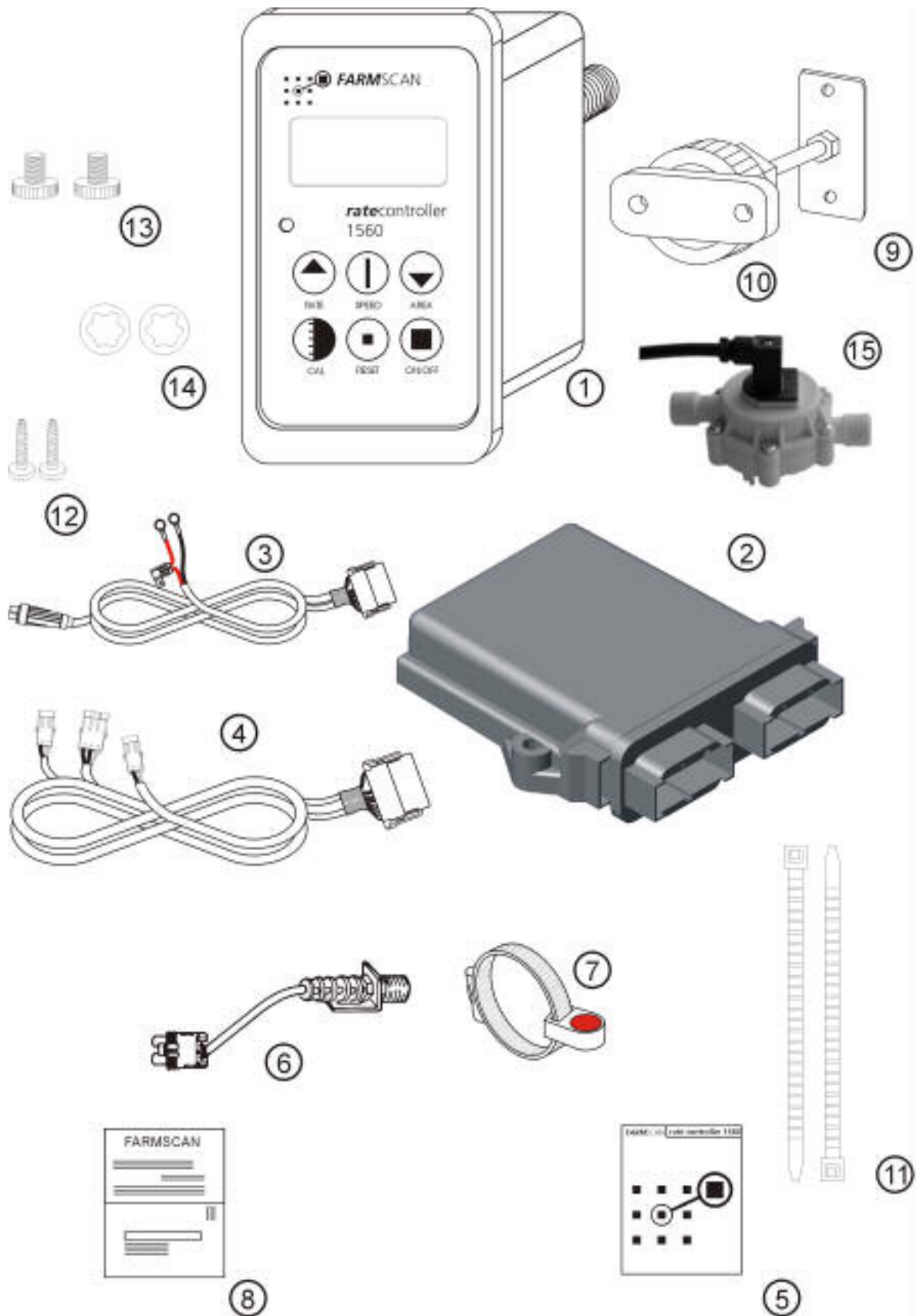

1.0 INSTALLATION

1.1 POWER CONNECTION

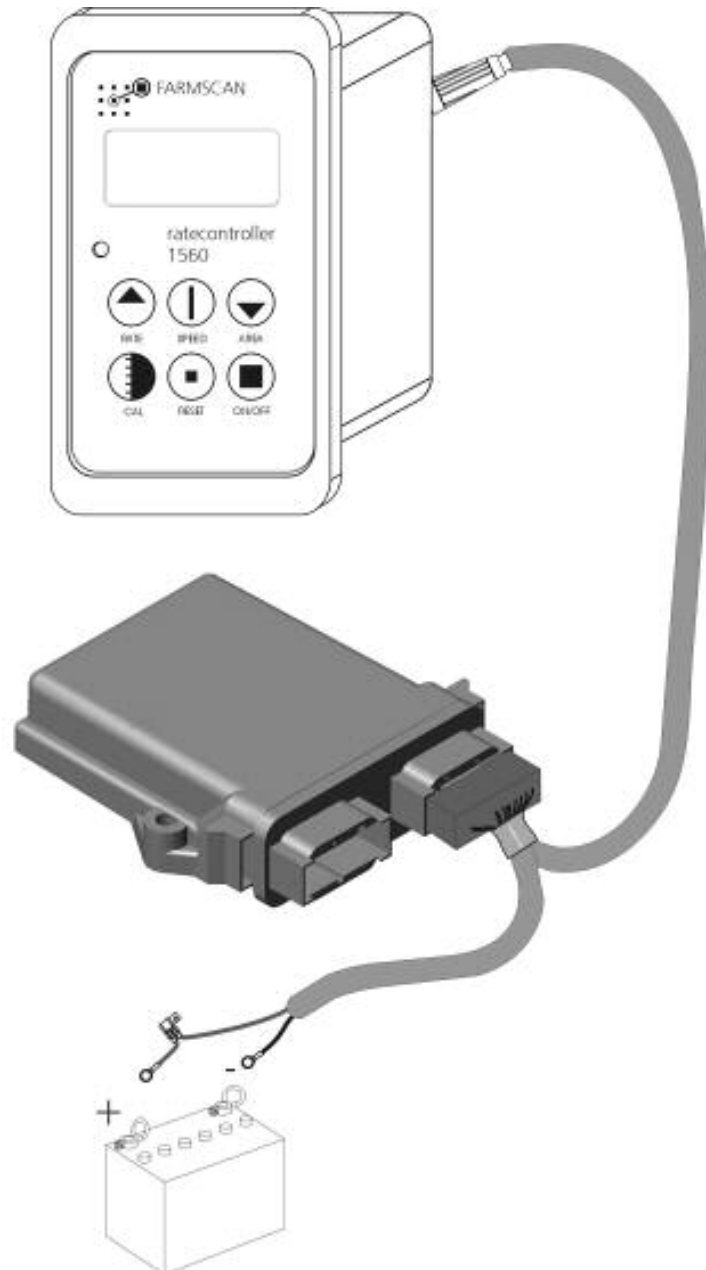

Use cable ties to secure Power cable away from risk of damage

DO NOT CONNECT OTHER EQUIPMENT TO MONITOR POWB CABLE - INTERFERENCE MAY RESULT.

DISCONNECT MONITOR POWER CABLE WHEN ARC WELDING ON MACHINERY.

SEE NEXT PAGE TO CONNECT TO BATTERY.

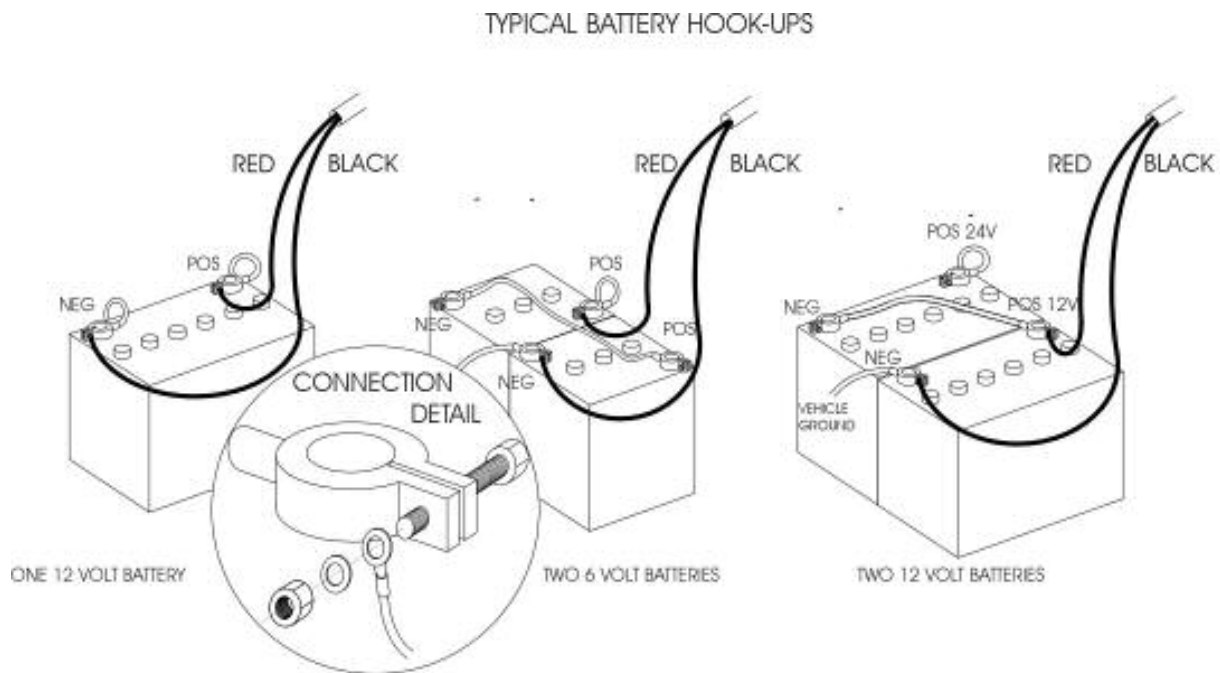

1.2 SENSOR & WIRING INSTALLATION

Install flow sensor and wheel sensor first, then lay out both wheel and flow sensor wiring looms on machine.

Secure both looms neatly with cable ties to avoid risk of damage.

Optional 5m and 10m loom extension cables are available if required (look at optional parts).

The tails from the Rate Controller Pod connects to the wheel sensor, flow sensor and pump. The 3 tails are labelled.

1.3 FLOW SENSOR INSTALLATION

The flow sensor must be installed in the main delivery line between the pump and the spray nozzles.

The operating flow rate must be in the range of the flow sensor fitted.

Other flow sensors are available through your Farmscan dealer. To handle different flow rates and pressures.

Check minimum & maximum L/MIN as follows:

$$\frac{\text{L/HA} \times \text{WIDTH} \times \text{SPEED}}{600} = \text{L/MIN}$$

Example:

$$\frac{300 \text{ L/HA} \times 4 \text{ M} \times 4 \text{ KPH}}{600} = 8 \text{ L/MIN}$$

There must be no return flow to tank after the flow sensor metering point, all the liquid being delivered to the target must pass through the flow sensor.

IMPORTANT:

Ensure flow direction arrow points in the same direction to flow.

1.4 WHEEL SENSOR INSTALLATION

The standard wheel sensor supplied with the rate monitor kit, consists of a reed type sensor and magnet to be fitted onto any undriven ground wheel.

The magnet activates the reed type sensor as it sweeps past.

WHEEL SENSOR INSTALLATION PROCEDURE

Clamp the shaft magnet around a ground speed related shaft or lock collar.

The clamp is adjustable from 19mm – 38mm in diameter. The magnet may be transferred to a larger clamp if necessary.

The sensor and magnet must face end to end.

As the sensor is not affected by moisture or mud the main precaution is to protect the sensor and cable from physical damage. Keep the wheel sensor cable away from aerial leads, engine kill switch cable or wires to electronic clutches and solenoid valves. Use cable ties to secure the wheel sensor cable.

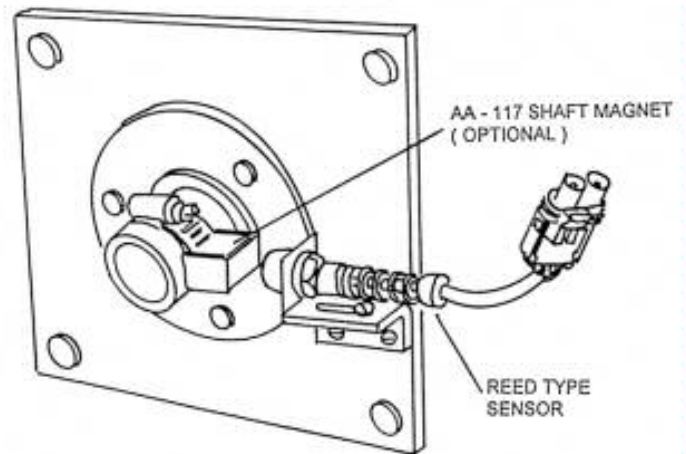

CALIBRATION

Before operating the rate controller you must establish and enter various calibration factors relevant to your sprayer.

Once entered in memory these factors will remain constant unless changed by the operator.

Follow the wheel and flow calculation procedure to determine these factors before proceeding to set up unit - See sections 2.1 and 2.2.

By pressing and holding the 'CAL' key you can go into the calibration menu.

Each time you press 'CAL', the next calibration option will be displayed

Use the 'UP' and 'DOWN' arrow keys to change a calibration number (factor) or setup on display.

The 'RESET' key can be used to zero any calibration factor on display.

If you wish to step back to a previous calibration option, you must keep pressing the 'CAL' key to exit the calibration menu and then press and hold the 'CAL' key and get back into the calibration menu from the beginning.

CALIBRATION WARNING

If calibration factors are corrupted the readout will display HELP to indicate that calibration factors must be checked.

2.1 WHEEL FACTOR CALCULATION

DISTANCE MEASUREMENT PROCEDURE (WHEEL SENSOR) - ONE WHEEL MAGNET

1. Align the wheel magnet and sensor
2. Mark bottom centre of tyre on which the sensor is fitted and peg ground in corresponding position
3. Move slowly forward and stop on exactly 10 tyre rotations.
4. Measure overall distance travelled and divide by 10 to get an average.

Example:

$$\begin{array}{rcl} 10 \text{ TURNS} & = & 23.45 \text{ METRES} \\ 23.45 \div 10 & = & 2.345 \text{ METRES / TURN} \end{array}$$

Therefore distance calibration factor = 2.345 metres

DISTANCE MEASUREMENT PROCEDURE (SHAFT SENSOR) – ONE SHAFT MAGNET

1. Align the shaft magnet and the sensor.
2. Peg the ground at the base of any tractor or implement wheel.
3. Move slowly forward and count exactly 10 rotations of the shaft.
4. Peg the ground again, at the base of the same wheel and measure the distance travelled. Divide the distance travelled by 10 to get an average.

Example:

$$\begin{array}{rcl} 10 \text{ TURNS} & = & 23.45 \text{ METRES} \\ 23.45 \div 10 & = & 2.345 \text{ METRES / TURN} \end{array}$$

Therefore distance calibration factor = 2.345 metres.

NOTE:

If using two wheel or shaft magnets you must remember that one rotation of either the wheel or shaft will mean that the sensor has been activated twice. Calculate as follows:

$$\begin{array}{rcl} 10 \text{ TURNS} & = & 20 \text{ sensor pulses} & = & 23.45 \text{ m} \\ 23.45 \div 20 & = & 1.172 \end{array}$$

Therefore distance calibration factor = 1.172 m

2.2 FLOWSENSOR FACTOR CALCULATION

Calibration factors will vary with liquid viscosity and different installations or flow sensor types and it is advised to check this figure before spraying chemicals.

IMPORTANT:

Disconnect a hose after the flow sensor that can be directed into a bucket. Preferably after a solenoid valve or another valve that can be used easily to stop and start the test. Follow the procedure below to test the flow sensors calibration factor.

FLOWSENSOR TEST METHOD

! WARNING - TAKE PRECAUTION TO AVOID SPLASHBACK INJURY

For best results, test should be carried out at normal operating flow rate.

1. Fully prime the flow sensor and hose before starting.
2. Prepare a container of known volume 10 Litres or more with accurate markings, or check quantity in a smaller measure jug.
3. Switch monitor on and press and hold the "CAL" key to display H1 and keep pressing the "CAL" key to display H5. 'RESET' to clear any figure displayed.
4. Start liquid flow into container and shut off flow exactly at desired point. The figure under H5 should stop counting.

Example:

1575

IMPORTANT !

H5 count will scroll from 0 to 9999. If you exceed 9999 pulses the display will start from 0 and count up again. Watch the pulse count carefully and add 9999 to the present pulse count to get the total pulses if the pulse count exceeds 9999.

Divide the total pulses by the measured quantity.

$$\begin{array}{rclcl}
 \text{eg} & \text{PULSES} & = & 1575 & \\
 & \text{LITRES} & = & 10.5 & \\
 & 1575 \div 10.5 & = & 150 \text{ Pulses Per Litre} &
 \end{array}$$

flow test method continued...

5. Repeat test a couple of times to check accuracy then record factor flow cal factor in H4 setting as explained in section 2.3.

2.3 ENTERING CALIBRATION FACTORS

1. Switch rate monitor ON and press and hold the "CAL" key to display H1 (Wheel calibration factor)

Example:

H1 0.500

2. Use "UP" or "DOWN" arrow keys to set distance factor in metres.

Example:

0.555

3. Press the "CAL" key again to display H2 (Width calibration factor)

Example:

H2 2.00

4. Measure effective implement WIDTH in metres and use the "UP" and "DOWN" keys to set width factor.

Example:

4.00

5. Press the "CAL" key again to display H3 (Target Rate Calibration Factor)

Example:

H3 50.0

6. Use the "UP" or "DOWN" arrow keys to set the target rate calibration factor in litres per hectare.

Example:

30.0

7. Press the "CAL" key again to display H4 (Pulses Per Litre Calibration Factor)

Example:

H4 150.0

8. Use the "UP" or "DOWN" arrow keys to set the pulses per litre calibration factor.

Example:

145.5

9. Press the "CAL" key again to display H5. This is used to check flow pulses. This is used when testing your flow sensors calibration.

10. Press the "CAL" key again to get you out of the calibration menu back into operate mode.

3.0 OPERATION

3.1 POWER ON / OFF KEY

Press the "ON / OFF" key for a full second to switch on rate monitor.
Whenever the unit is switched on the rate reading will be displayed first.

From this point you can select any other key.

3.2 SPEED KEY

Press the 'SPEED' key once to display ground speed

Example:

14.6 KPH

3.3 AREA KEY

Displays the total hectares which can be reset at any time.
Maximum total reading is 9999

3.4 RATE KEY

Displays the actual rate, in litres per hectare being sprayed.

3.5 RESET KEY

After selecting AREA, holding the RESET key down for approx. 3 seconds will clear the readout back to zero.

The RESET key can also be used to clear calibration factors to zero.

3.6 MEMORY BACKUP

The total area reading is automatically stored in permanent memory when the unit is switched OFF using the ON/OFF key.

The inbuilt memory system will hold all calibrations and area in memory for at least 1 month after disconnection from the 12 volt power source.

3.7 RUN HOLD FUNCTION

You can automatically put the monitor on hold by switching the “run/hold” switch on the side of the rate controller. This is the bottom switch when looking at the rate controller display. When the switch is in the hold position, power to the pump will be off, area will stop accumulating and the rate will drop to zero. When the switch is in the run position, power to the pump will resume, area will start accumulating and the rate will be displayed.

3.8 AUTO / MANUAL FUNCTION

You can automatically put the unit in auto mode or manual mode by switch the “auto/manual” switch on the side of the rate controller. This is the top switch when looking at the rate controller display. When the switch is in the auto position, the rate controller will maintain the target rate regardless of any change in ground speed. When the switch is in the manual position, a constant 12 volts will be sent to the pump, resulting in flow going into maximum pessure.

4.0 TROUBLESHOOTING 1560 RATE CONTROLLER

PROBLEM	POSSIBLE CAUSE / REMEDY
1. NO POWER TO MONITOR WHEN ON / OFF KEY PRESSED	a) Test voltage at power cable is 12 - 13.8V dc from battery. b) Check that red wire is to battery positive and black wire is to battery negative. c) Check that no other electrical device is connected to the same power cable. d) Unable to locate fault - Contact nearest Dealer or Authorised Service Agent.
2. MONITOR SWITCHES ITSELF OFF.	a) If display rectifies when engine running this indicates battery in poor condition or dirty connections. b) If problem persists when engine running, then voltage supply is low or low current is problem due to poor connection at battery or other equipment connected to power cable. c) Clean battery terminals and power cable connections. d) Make sure power cable is <u>direct</u> to battery terminals.
3. SPEED READOUT TOO FAST OR TOO SLOW	a) Re check "WHEEL" Calibration is measured correctly and measured in Metres eg 2.445 metres.
4. SPEED READOUT JUMPY	a) Make sure magnet is facing sensor correctly as shown in section 1.4 "WHEEL SENSOR INSTALLATION". (Use of an alternative magnet may cause problems due to wrong orientation.) b) If two magnets used, problems could be uneven spacing of magnets. c) Check that Wheel Magnet is 15 - 20 mm away from Wheel Sensor as they pass. Magnet too close can cause jumpy speed. d) If readout is jumpy, it indicates that the impulses from the sensor are inconsistent. Check for poor or intermittent connection to sensor. e) Is the magnet staying in line with sensor on corners?

TROUBLESHOOTING 1550 RATE MONITOR

PROBLEM		POSSIBLE CAUSE / REMEDY
6. SPEED READOUT STAYS AT ZERO	<ul style="list-style-type: none"> a) b) c) d) e) f) g) 	<p>Check wheel calibration is set correctly - not zero.</p> <p>Check clearance between wheel magnet and sensor is 15 - 20mm.</p> <p>Press 'SPEED' key to display ground speed then disconnect sensor at furthest point from monitor</p> <p>Use a short piece of wire or long nose pliers to intermittently short circuit pins corresponding to black and white wires of wheel sensor cable.</p> <p>If the monitor displays a speed the wiring is ok- replace sensor.</p> <p>If no response repeat short circuit test at the monitor. If a speed is displayed then the fault is in the cable.</p> <p>If no response, return monitor to your nearest Farmscan dealer or authorised Farmscan service agent.</p>
7. WHEEL SENSOR TEST PROCEDURE	<ul style="list-style-type: none"> a) b) c) d) 	<p><u>DO NOT TEST WHEEL SENSOR WITH A TEST LIGHT, USE A MULTIMETER ONLY.</u></p> <p>Disconnect wheel sensor from cable.</p> <p>Switch Multimeter "ON" and select "OHMS" scale.</p> <p>Touch test probes together and meter needle should swing to right of scale indicating "0" OHMS resistance. (If digital meter display - should read zero).</p> <p>Move wheel sensor magnet away from sensor and connect test probes to wheel sensor pins. If meter goes to zero, then sensor is short circuit (faulty). If the meter stays to the left of scale, move wheel magnet in front of sensor, meter should go straight to zero. If meter fails to change, then sensor is open circuit. (faulty)</p>
8. AREA INCORRECT OR WON'T RECORD	<ul style="list-style-type: none"> a) b) c) d) 	<p>Check "SPEED" readout is correct and steady - if not, this will affect the area totals. See Troubleshooting Section 4, 5 or 6</p> <p>Recheck width calibration is set correctly in <u>metres</u>.</p> <p>Is the machine overlapping or over counting headlands.</p> <p>Is the monitor off HOLD?</p>

TROUBLESHOOTING 1550 RATE MONITOR

PROBLEM	POSSIBLE CAUSE / REMEDY
9. NO RATE READOUT	a) Check 'SPEED' readout, if no speed follow Troubleshooting 6 & 7. b) Check correct calibration of width. See 2.3. c) Check flow cal setting is correct in H4. See section 2.2 & 2.3. d) Disconnect flow sensor from main loom and enter into the H5 calibration option. Use a pair of long nosed pliers to intermittently short out across pins A (white) and B (black) of flow sensor loom connector plug back to monitor. DO NOT TOUCH PIN C RED! + 12 Volts Monitor should start counting pulses. If OK follow Troubleshooting 11 If still no response direct into monitor then return monitor for service.
10. NO RATE READOUT	a) Check connection of plug into monitor. b) Check voltage across pin C & B on 3 pin flow sensor input plug at the pod. (C=red and B=black). c) Check voltage into flow sensor is 12 - 14 volts between red and black wires at flow sensor connector plug of loom. If voltage OK, and sensor still fails, return sensor to your nearest Farmscan dealer or authorised service agent.
11. NO RATE READOUT	a) Disconnect flow sensor from sprayline and check Inlet for blockage. b) Blow softly into Inlet (without mouth contact) and check that turbine spins freely. c) If turbine jammed then flow sensor needs servicing. d) Return flow sensor to your nearest Farmscan dealer, authorised service agent.
12. UNABLE TO LOCATE FAULT	a) Contact nearest Farmscan Dealer b) Contact Computronics Corporation Ltd 6 Sarich Way Technology Park Bently Western Australia 6102 PH: +61 8 9470 1177 FAX: +61 8 9470 2844 EMAIL: service@farmscan.net.au

5.0 INTERFERENCE CAUSES AND REMEDIES

CAUSES	REMEDIES
Noisy wire ignition leads on petrol engine or pump motor.	Replace with Carbon leads. Fit suppressors to coil and distributor.
Faulty Alternator	Exchange it
Other electrical equipment running off monitor power cable	Run separate power cable DIRECT to 12V battery for Monitor.
Calibrations get corrupted when solenoids / clutch switched off.	Make sure Monitor has its own separate Power Cable direct to 12V Battery. Fit diode across solenoid coil / clutch to clamp spike. Run power cable Physically away from solenoid / clutch wiring.