

# Installation and Operation Instructions



# CONTENTS

COMPONENT LIST.....	2
COMPONENT PICTORIAL.....	3
GENERAL INFORMATION.....	4
POWER CONNECTION.....	5
BOOM CONTROL INSTALLATION.....	6
JUNCTION BOX INSTALLATION.....	7
CABLE INSTALLATION.....	7
SOLENOID CONNECTIONS.....	9
SOLENOID INSTALLATION.....	9
2405 BOOM CONTROL OPERATION.....	10
JUNCTION BOX OPERATION.....	12
SOLENOID MAINTENANCE.....	13
TROUBLESHOOTING.....	15

## COMPONENT LIST - 2405 BOOM CONTROL KIT

REF	PART No.	DESCRIPTION	QTY
1	A-2405	5 SECTION BOOM CONTROL PANEL	1
2	AH-415	MONITOR MOUNTING BRACKET	2
3	AH-861	FINGER SCREWS (1/4")	2
4	AH-411	MEDIUM EXTENSION BRACKET	2
5	HG-005	ADHESIVE WASHER 10x7x1.5	2
6	AC-033	2400 COMMS CABLE (SHORT)	1
7	AC-031	2400 COMMS CABLE (LONG)	1
8	AC-014	17M JUNCTION BOX COMMS CABLE	1
9	AC-108	20M HEAVY DUTY POWER CABLE	1
10	A-2405J	SOLENOID JUNCTION BOX	1
11	AP-105	12 PIN BRYLITE PLUG	1
12	AP-106	12 PIN BRYLITE SOCKET	1
13	AC-040	AUXILIARY POWER LEAD ADAPTER	1
14	AC-101F	8M FUSED BATTERY POWER CABLE	1
15	HG-706	CABLE TIES 290 x 5mm	20
16	AH-408	UNIVERSAL HARDWARE PACK	1
17	AM-2405	2405 INSTRUCTION MANUAL	1
18	AM-200	FARMSCAN WARRANTY CARD	1

# ! IMPORTANT !

THE 2405 BOOM CONTROL IS ONLY COMPATIBLE WITH THE

## 2400 SPRAY CONTROLLER

FITTED WITH

## VERSION 3.0 SOFTWARE

OR LATER.

**NOTE:**

OLDER SPRAY CONTROLLERS CAN BE UPDATED IF NECESSARY

# COMPONENT PICTORIAL - 2405 BOOM CONTROL KIT

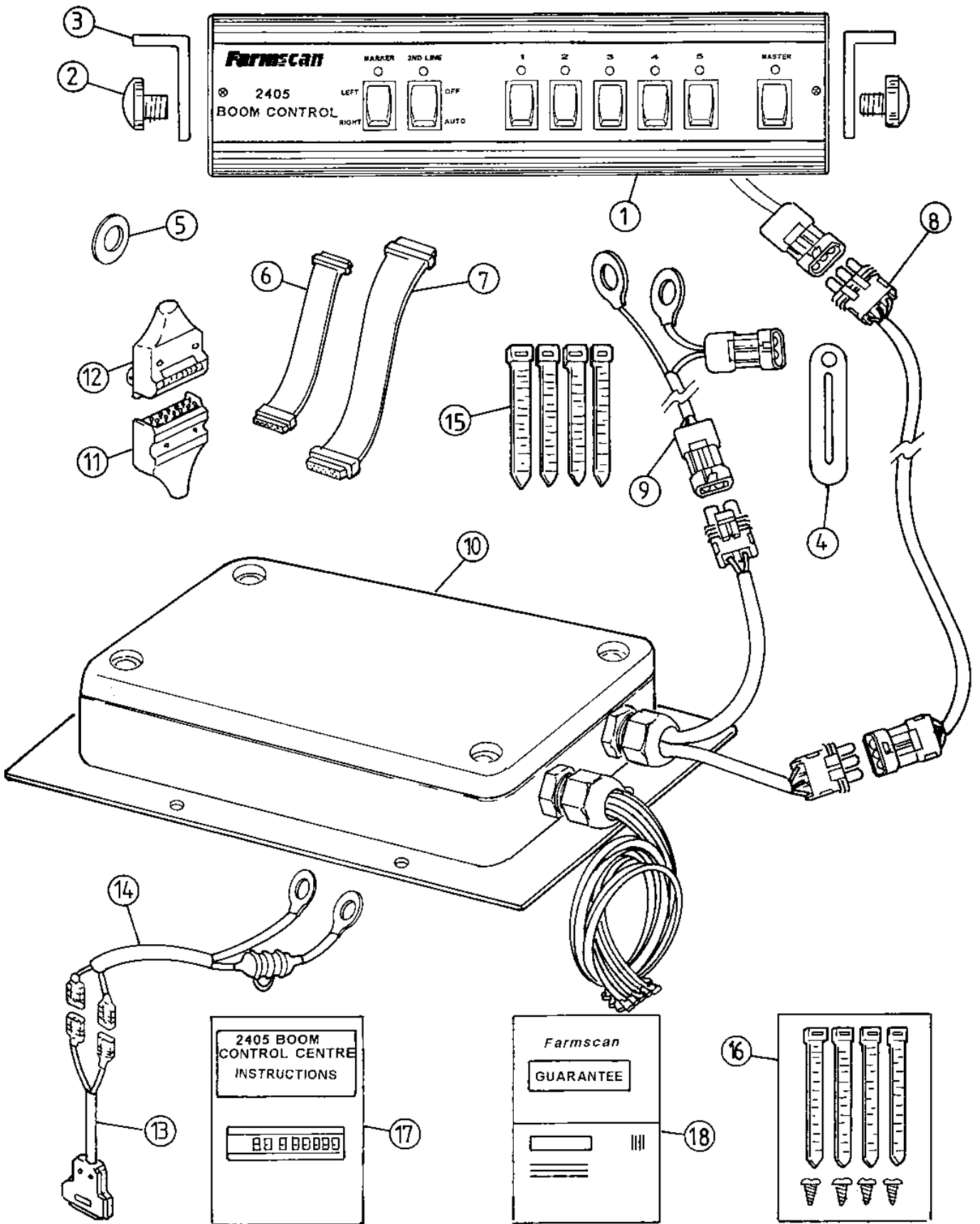

## GENERAL INFORMATION

The 2405 BOOM CONTROL panel provides switching for up to five boom section solenoids plus left and right foam marker solenoids and a second sprayline solenoid.

A remote junction box is connected to the control panel via a simple 3 wire communication link that sends control messages to activate relays housed in the junction box. A separate heavy duty power feed connected to the junction box provides a 12 volt power source switched by the relays to the solenoid valves.

The 2405 system is normally used in conjunction with a 2400 Spray Controller which automatically compensates when boom sections are switched off. A second sprayline (if used) is automatically activated by the 2400 at a preset speed and may be over ridden using the 2nd sprayline switch on the 2405 Boom Control panel.

When the 2405 is used as a standalone system, the boom sections and second sprayline solenoids can be switched on or off at any time but the operator must make manual adjustments of pressure to compensate.

In the event of damage to the communication cable, the relays can be manually activated with **jumper** links inside the junction box.

A choice of 3 types of 'NORMALLY CLOSED" 12 volt solenoid valves are available to us with the 2405.

Part #	Description	Max Flowrate (L/min)	Oper. pressure (KPA)	Inlet/ Outlet size	Thread	Details
AH-489	Blue Solenoid Valve	22	20 - 1000	3/4" Male Thread to 1/2" Hose Barb	BSP	suits smaller booms or fenceline jets
AH-490	Black Solenoid Valve	30	15 - 1400	3/4" Male Thread to 3/4" Male Thread	BSP	Suits most applications.
AH-492	Large Solenoid Valve	56	34 - 700	1" Female Thread to 3/4" Female Thread	NPT	High flow, top quality

Please use the following formula to determine flow rate requirements for each boom section.

$$\frac{\text{MAX. RATE (LHA)} \times \text{TOP SPEED (KPH)}}{600} \times \text{SECTION WIDTH (M)} = \text{SECTION FLOWRATE (LPM)}$$

Please follow the instructions carefully to ensure proper installation.

## POWER CONNECTION

Do not connect power until all other installation is complete.

The 20 metre **heavy duty power cable** (for junction box) must be connected **direct** to 12 volt DC vehicle battery terminals and not joined together with spray controller power cable or any other source.

If the trailed sprayer has its own 12 volt battery, you may connect directly to the sprayer battery.

Mount inline fuse holder securely, **close to positive** battery terminal. Fuse holder must not be removed.

### IMPORTANT:

For **standalone** operation of the 2405 Boom Control it is also necessary to install the second auxiliary power lead connected from the battery to the 2405 boom control panel - see Page 5.

**Use** cable ties supplied to secure power cable away from risk of damage & short-circuit.

Connection to battery terminals must be clean and tight.

### WARNING

Disconnect power cables from battery when arc welding on machinery as damage to the equipment may result.

### TYPICAL BATTERY HOOK-UPS

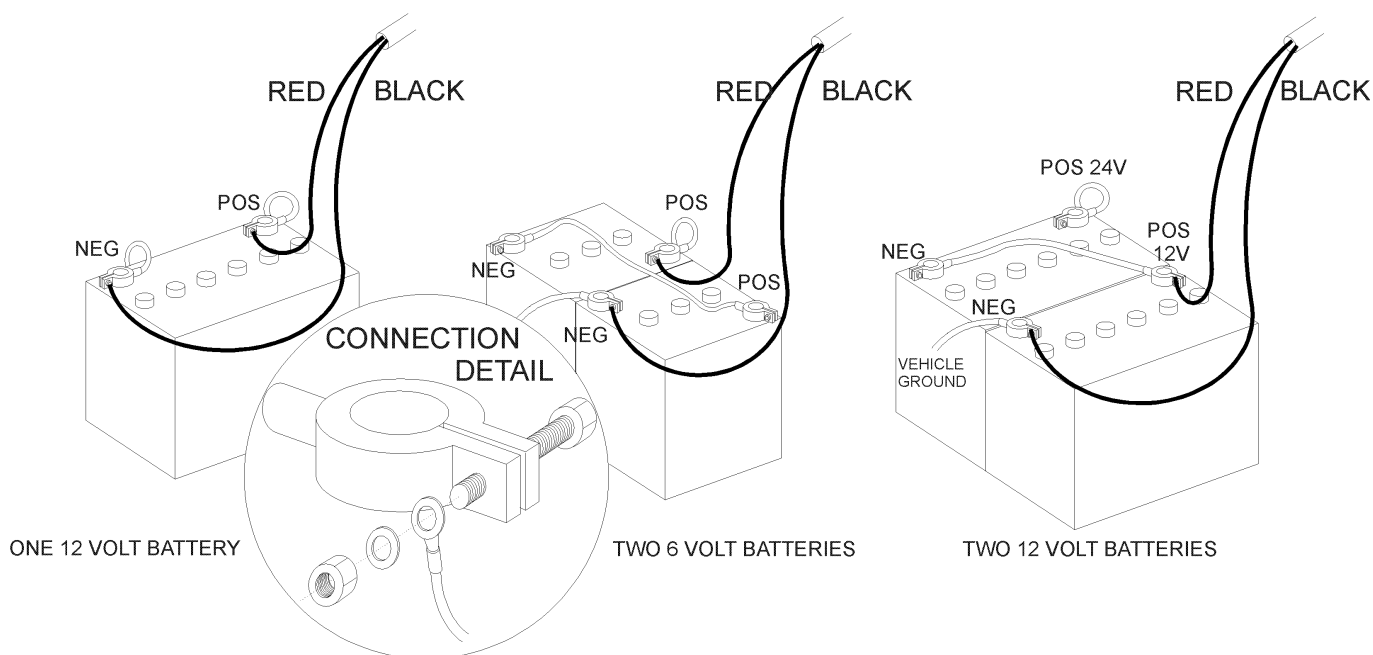

## BOOM CONTROL INSTALLATION

### WITH 2400 SPRAYCONTROLLER

Mount the 2405 Boom Control Panel in cab for ease of viewing and easy operator access.

If desirable, mount 2405 Boom Control above or below 2400 Spray Controller using "medium extension brackets" labelled as component number 4 on page 2.

There are two adhesive rubber washers included in the kit to provide a fixed angle for the extension brackets from the 2400 Spray Control to the 2405 Boom Control

The boom control panel is not weather proof and must be installed in a sheltered environment.

Connect 2400 comms cable from rear of 2405 Boom Controller to the 9 Pin connector on the rear underside of the 2400 Spray Controller (choose either the 'short' or 'long' 2400 comms cable).

### STAND-ALONE OPERATION

Simply mount the 2405 Boom Control unit in cab for ease of viewing and easy operator access using the two mounting brackets supplied in the kit.

Connect "auxiliary power adaptor lead" to 9 Pin port on rear of 2405 Boom Control.

This power lead can be connected to any 12V D.C. power source and requires a separate switch inline to isolate power from the boom control panel.

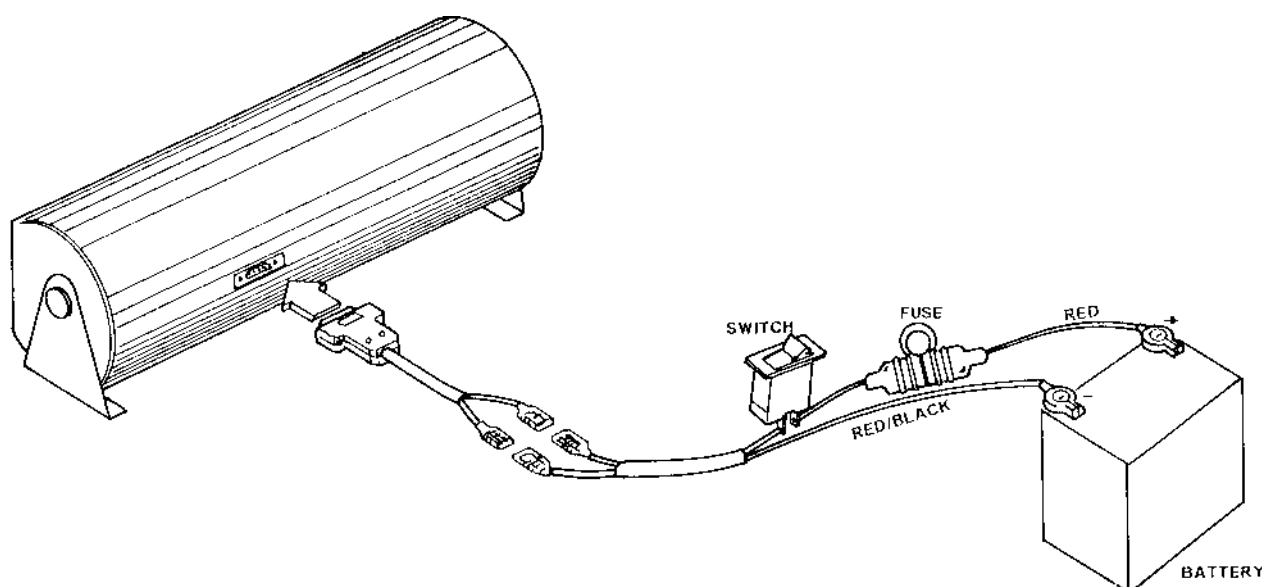

#### NOTE:

If the 2400 spray controller fails, the auxiliary power adaptor must be used to allow the 2405 Boom Control to be used independently. **Keep the adaptor in a handy location!**

## JUNCTION BOX INSTALLATION

The junction box should be installed within 1 metre of the boom section solenoid valves in a sheltered mounting position to reduce the dependence on sealing. Do not use silastic to seal box - corrosive fumes can damage the circuit.

Care must be taken to ensure the junction box remains fully sealed around the lid and cable entry points if exposed to direct weather.

Use the Metal Bracket on the Junction box to mount the Unit. **Do not drill holes in the plastic box.**

Ensure the unit is mounted upright as shown in the diagram. There are four drain holes at the base of the unit which need to face the bottom to help disperse moisture.

**DO NOT DRILL HOLES IN JUNCTION BOX UNDER ANY CIRCUMSTANCES.**

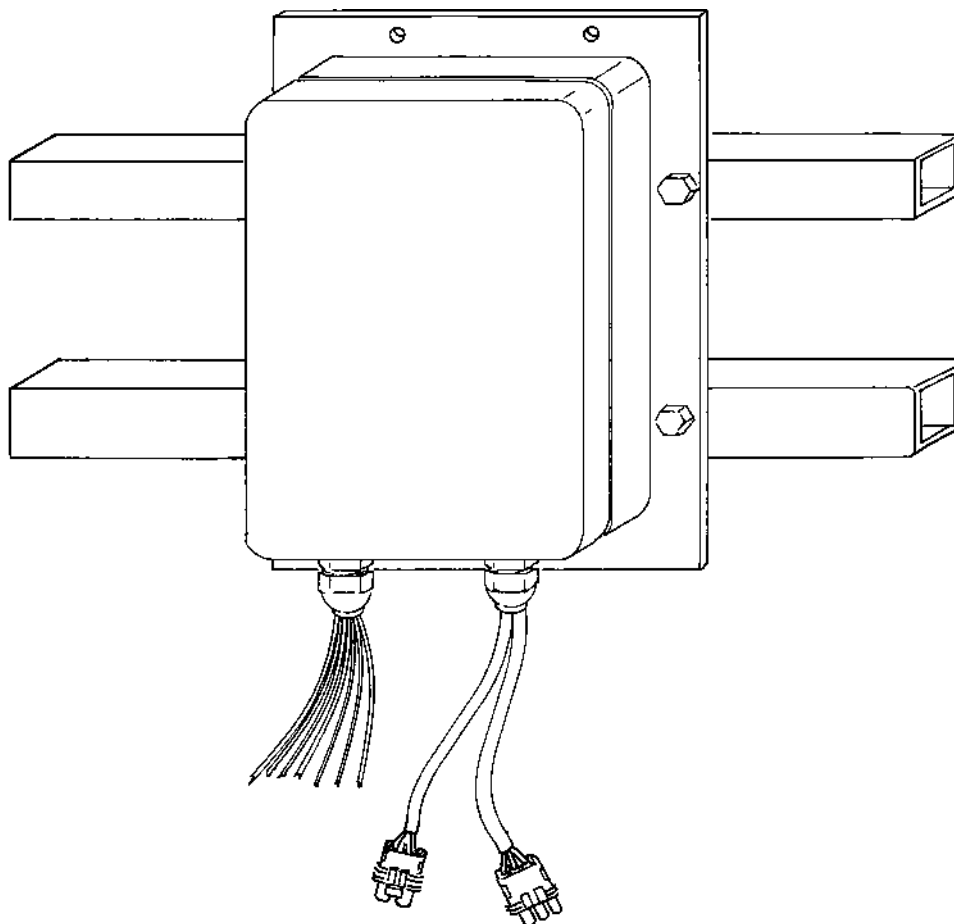

## CABLE INSTALLATION

Run the 17m junction box comms cable from 3 way tail of the 2405 boom control unit to the 3 pin communications tail on solenoid junction box.

Use cable ties to ensure cable is secured away from moving parts and any possible damage.

Connect heavy duty power cable from battery to matching 2 pin power tail on junction box.



## CABLE INSTALLATION CONTINUED

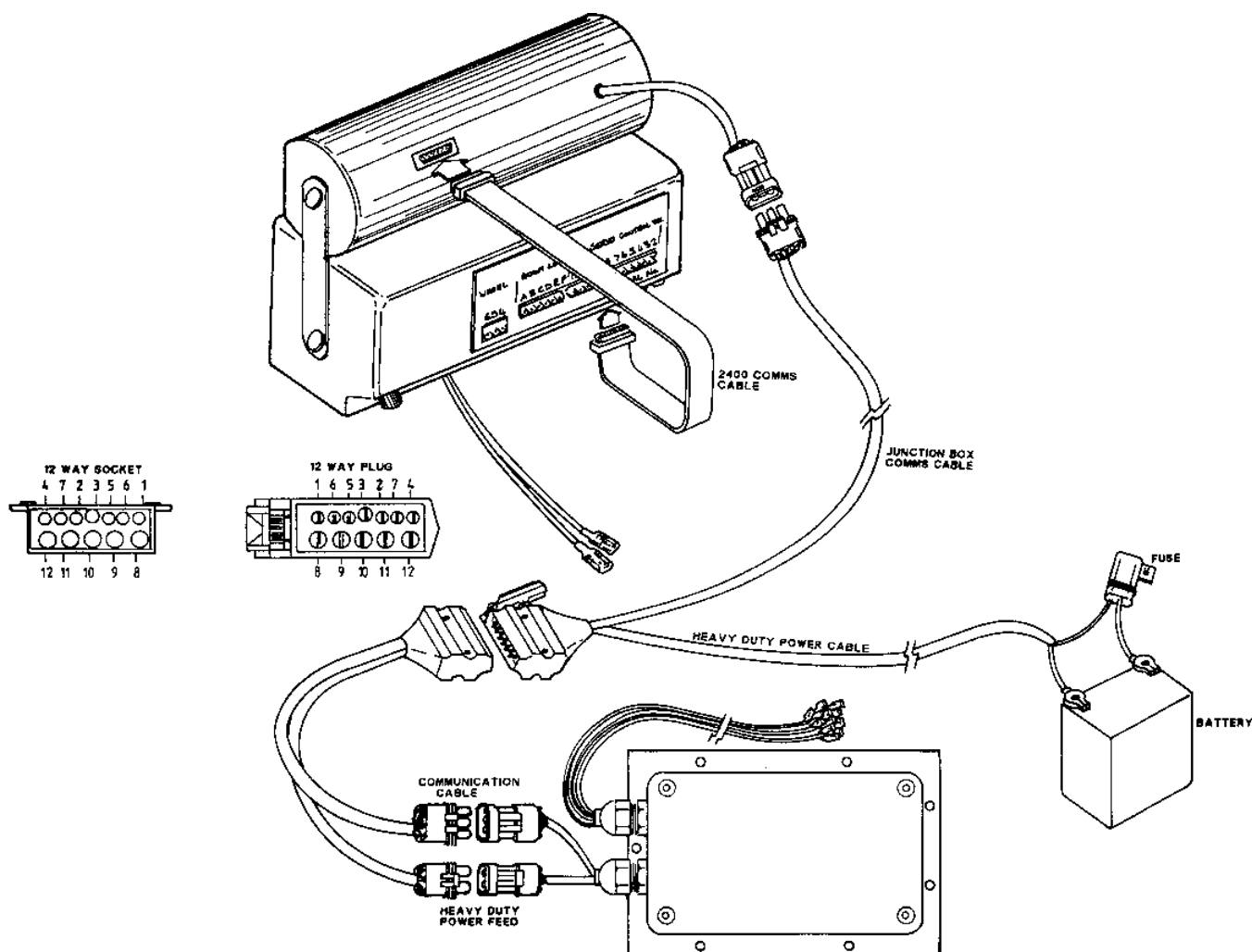

## BREAKAWAY INSTALLATION

If installing the solenoids on a trailed boom, ensure all power is disconnected first.

- Cut serial communications cable and heavy duty power cable at rear of towing vehicle to the required length.
- Use 12 way **plug** on towing vehicle side to avoid mix up with 12 pin socket from spray controller breakaway.
- Pin allocations for 12 way connection given in chart.
- Fit 12 Way **socket** to sprayer side of cable making sure to allow enough slack cable for turning.

12 WAY BRYLITE CONNECTOR	
Pin	Colour
1	white
2	black
3	red
4	Not Used
5	Not Used
6	Not Used
7	Not Used
8	Not Used
9	RED (PWR)
10	Not Used
11	BLACK (PWR)
12	Not Used

## SOLENOID CONNECTIONS

Follow the table and diagram below to connect each solenoid to the correct output.

OUTPUT	CABLE COLOUR
LEFT FOAM MARKER	BROWN / BLACK
RIGHT FOAM MARKER	RED / BLACK
2ND SPRAY LINE	ORANGE / BLACK
SECTION SOLENOID 5	YELLOW / BLACK
SECTION SOLENOID 4	GREEN / BLACK
SECTION SOLENOID 3	BLUE / BLACK
SECTION SOLENOID 2	VIOLET / BLACK
SECTION SOLENOID 1	GREY / BLACK

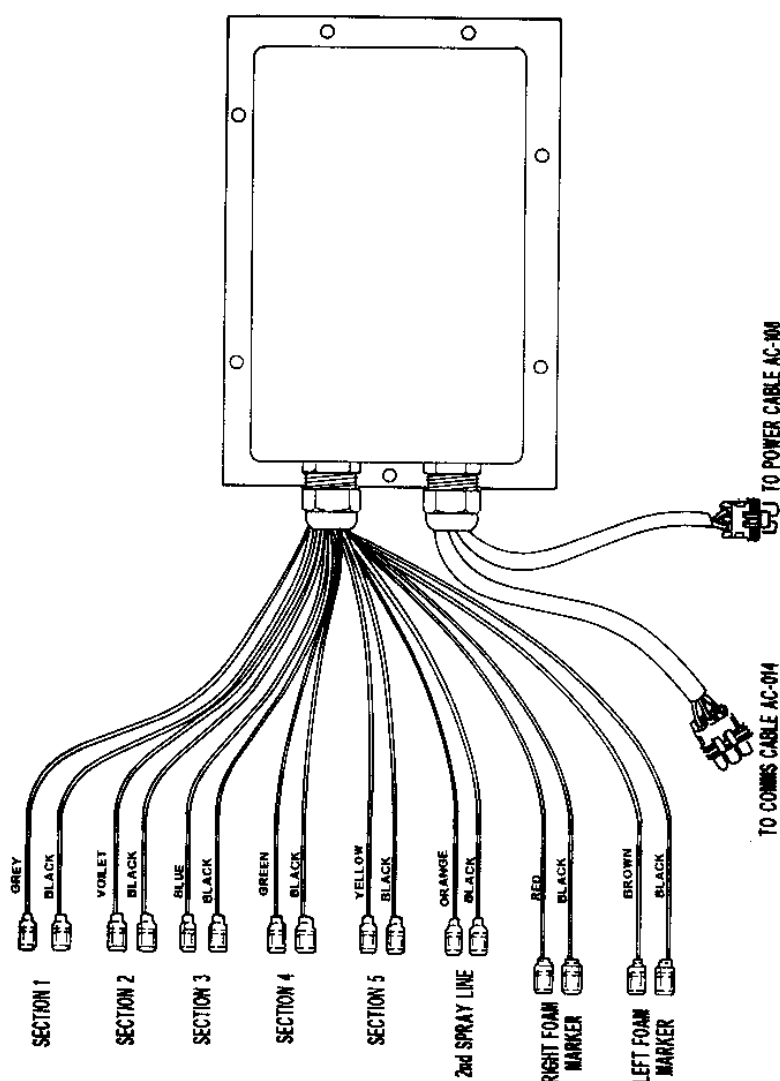

## SOLENOID INSTALLATION

Mount solenoid valves close to solenoid junction box in a bank downstream from the flowsensor. Depending on solenoid type, a manifold may be made up using elbows and tee pieces to suit your plumbing. Feed hoses to boom sections should be sized according to solenoid output size, eg. 1/2" or 3/4".

## 2405 BOOM CONTROL OPERATION

If connected to the 2400 Spray Controller using the 2400 comms cable, the Spray Controller power switch must be 'ON' to provide power across to the 2405 control panel.

If used without the 2400 Spray Controller, the auxiliary power switch must be 'ON'.

### Master Switch

The Master Switch over rides all control panel switches to provide instant on/off control over all functions.

The Master Switch light has three possible modes to indicate the boom control status.

1. GREEN: indicates **normal** mode - full communication established both to the 2400 and to the junction box
2. RED: after 5 seconds indicates **standalone** mode - no communication with 2400, but communication to junction box established.
3. FLASHING AMBER: indicates **no communication** with the solenoid junction box - refer to Troubleshooting.

### Boom Section Switches

Separate switches control sections 1-5 indicated by a green light above each switch.

When connected to a 2400 spray controller, the number of active sections and width of spray governed by each section must be entered during calibration. The 2400 will then automatically compensate when individual sections are shut down or activated on-the-go.

Turning the 'MASTER' switch 'OFF' will cause the 2400 to hold pressure at that point. This is useful at headlands and should be done before reducing ground speed.

#### IMPORTANT:

When used in **standalone** mode without a 2400 Spray Controller, the operator must make manual adjustments to pressure when sections are shut down or activated.

## 2405 BOOM CONTROL OPERATION CONTINUED

### Second Spray Line

The second sprayline function is normally used in conjunction with a 2400 Spray Controller which sends a signal through the 2405 control panel to automatically activate the second line solenoid at a preset point.

Place the "2ND LINE" switch in the 'AUTO' position to allow the function to work normally.

The 'OFF' position over rides 'AUTO' to disable the 2nd line function at any time.

To activate the 2nd line when stationary, switch to 'AUTO', then switch the spray controller servo switch to **open**.

Refer to spray controller 2nd line calibration instructions to set 2nd line activation point.

### Foam Marker

The Foam Marker switch has 3 positions;

UP:	LEFT foam marker solenoid active.
CENTRE:	OFF.
DOWN:	RIGHT foam marker solenoid active.

#### **NOTE:**

To operate foam marker when stationary, switch all sections OFF and switch MASTER 'ON'.

## JUNCTION BOX OPERATION

The junction box operates by control messages sent down the 3 wire communication cable from the 2405 Control Panel to tell the junction box which relays are to be activated.

The control panel switches **do not** directly switch voltage to the relays.

A separate heavy duty power cable provides supply voltage to the junction box which is relayed out to the solenoids.

Inside the junction box you will see a red light that illuminates when power is applied to the 2405 Boom Control Panel. The red light should activate when the 2400 Spray Controller power switch is 'ON' regardless of the boom control 'MASTER' switch. The red light **does not** indicate heavy duty power is available.

Adjacent to each solenoid connection is a green light that illuminates when each switch is activated. The green light will not illuminate if heavy duty power is disconnected or if a fuse has blown.

### Manual Over Ride

In the event of communication failure between the 2405 Boom Control Panel and the junction box, you can jump power out to the solenoids by shifting the 10 Amp fuse to the over ride position as shown.

The green light will remain 'ON' in the over ride position.

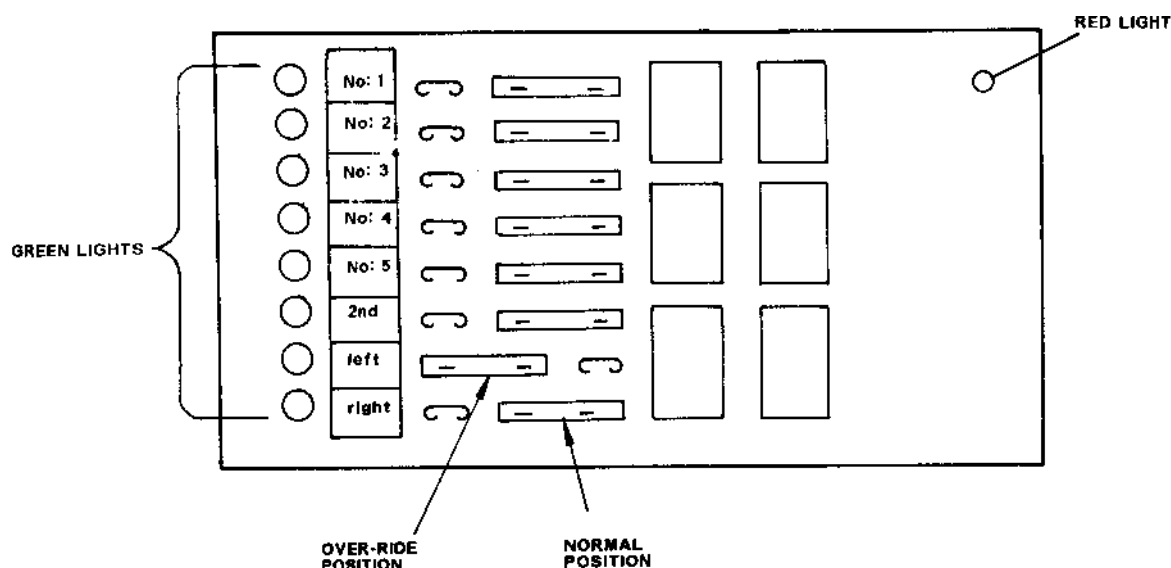

### IMPORTANT:

When using over ride, the 2405 comms cable connected to the 2400 Spray Controller must be DISCONNECTED. Calibration of the 2400 must be set for 1 SECTION operation with the whole WIDTH programmed as one section.

Do not shut down sections on-the-run. Disconnect heavy duty power to disable the solenoids.

## SOLENOID MAINTENANCE

1. Flush spraylines and solenoid valves daily with fresh water.
2. Ensure electrical connections to coil remain clean and firm.
3. If solenoid jams open or closed, disassemble solenoid and clean diaphragm venting hole.
4. If coil fails solenoid can be used temporarily by removing the plunger. This means the solenoid will remain **on** with the flow controlled by the servo valve.

### BLUE SOLENOID AH – 489

- 22 Litres per minute maximum flow rate.
- 20 - 1000 KPA operating pressure range.
- 3/4" to 1/2" inlet to outlet size
- Suitable for smaller booms and fenceline jets.

#### IMPORTANT!

When reassembling solenoid ensure spacer is fitted as shown otherwise solenoid will not activate.

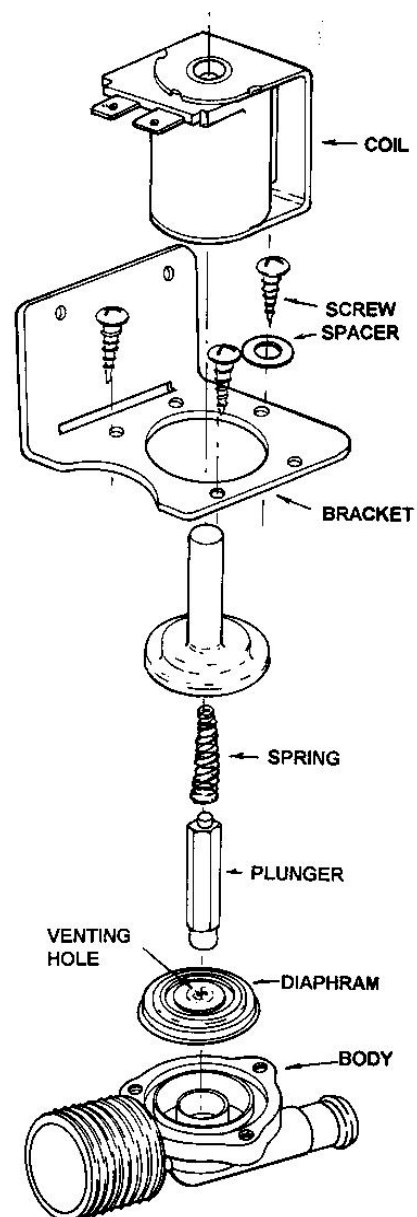

## SOLENOID MAINTENANCE Cont.

### BLACK SOLENOID AH - 490

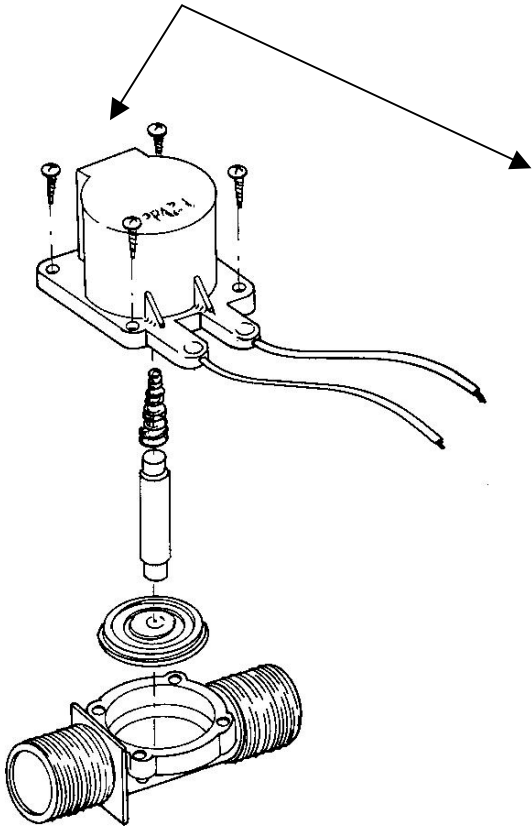

- 30 Litres per minute maximum flow rate.
- 15 - 1400 KPA Operating Pressure.
- 3/4" to 3/4" inlet to outlet size.
- Suits most applications.

### LARGE SOLENOID AH - 492

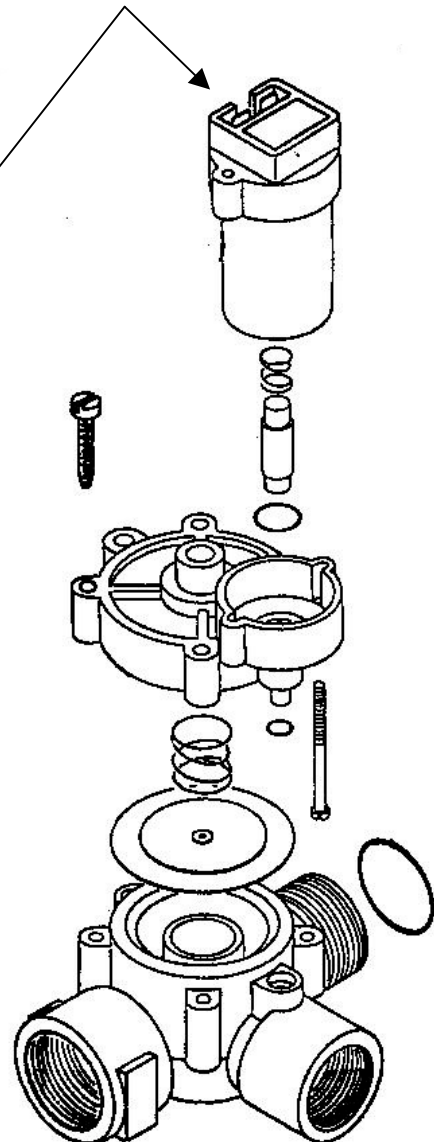

- 56 Litres per minute maximum flow rate.
- 34 - 700 KPA operating pressure.
- 1" to 3/4" inlet to outlet size.
- High flow, top quality.

## TROUBLESHOOTING - 2405 BOOM CONTROL

PROBLEM	POSSIBLE CAUSE / REMEDY
<p>1. NO POWER LIGHT WHEN "MASTER" SWITCH 'ON' AND/OR NO RED LIGHT IN JUNCTION BOX</p>	<p><b>With 2400 Spray Controller</b></p> <p>a) Check 2400 Spray Controller switched ON.</p> <p>b) Check 9 pins COMMS plug in rear of boom control and at rear underside of spray controller is inserted properly.</p> <p>c) Replace COMMS cable with spare long or short lead not used from original kit.</p> <p>d) If still no response, remove COMMS cable and replace with Auxiliary Power Adaptor Lead connected direct to battery.</p> <p>e) If 2405 works on direct power then fault either in COMMS lead or 2400 Spray Controller. If no response from 2405 on direct power then fault in 2405.</p> <p><b>Stand-Alone Operation</b></p> <p>a) Check auxiliary power cable with test light or test meter for 12 - 13.8 V DC at boom control end.</p> <p>b) If fuse holder in power line, then check fuse and check for corrosion as possible cause</p> <p>c) If power available and still no response return boom control for service and follow d) below.</p> <p>d) Follow junction box over ride instructions to continue operation – page 12.</p>
<p>2. MASTER LIGHT <u>RED</u> INSTEAD OF <u>GREEN</u></p> <p>AND "COMMS ERROR" ON 2400 DISPLAY</p>	<p>a) Indicates connection problem between 2405 and 2400 Spray Controller COMMS cable.</p> <p>b) Replace COMMS cable using spare long or short lead Not used from original kit.</p> <p>c) If still no response from <b>green</b> light then fault could be either in 2400 or 2405 COMMS circuitry - return both units for service.</p> <p>d) To continue operating <u>without</u> COMMS connection, remove COMMS cable, switch 2400 to "CALIBRATE" mode, press "TOTAL AREA" key to select "SECTIONS" and use ↓ key to select 1 SECTION only. Now press "TOTAL AREA" again to select "WIDTH" and use ↑ ↓ keys to set <u>total operating width of boom</u>.</p> <p>Resume operation of boom control panel by using "MASTER" switch only to turn whole boom on/off and use 2400 servo switch to close down valve.</p> <p>Do not shut down individual sections - over application will result.</p>



PROBLEM	POSSIBLE CAUSE / REMEDY
3. MASTER LIGHT FLASHES AMBER	<p>a) Indicates loss of communication between 2405 Boom Control Panel and junction box on 3 wire junction COMMS cable.</p> <p>b) Thoroughly check COMMS cable at all points between 2405 and junction box for physical damage or connection fault. Carefully tweak pins of male breakaway plug (if used) at drawbar.</p> <p>c) If Red light inside Junction Box is 'ON' then fault with white wire of COMMS cable.</p> <p>d) If unable to rectify use spare unit to isolate faulty component or return both 2405 and Junction Box as fault could be either end.</p> <p>e) To keep spraying without COMMS cable, follow Manual Over Ride instructions on page 12 of manual.</p>
4. SOLENOID VALVE FAILS TO ACTIVATE	<p>a) If "MASTER" light flashing <b>amber</b> follow Troubleshooting 3.</p> <p>b) If <u>all</u> solenoids fail, then fault probably with heavy duty power cable, if <u>one</u> solenoid fails only go to (e).</p> <p>c) Check and replace fuse at battery end of power cable - 20 amp max.</p> <p>d) Thoroughly inspect heavy duty power cable at all points for physical damage or connection broken using voltmeter or testlight.</p> <p>e) If power OK into junction box then check activation of <b>green</b> light adjacent to suspect solenoid terminal.</p> <p>f) If <b>green</b> light activates then fault with solenoid wiring or solenoid itself – swap solenoid wires with active solenoid to isolate cause of fault.</p> <p>g) If <b>green</b> light fails, swap or replace fuse and if still fails follow manual over ride instructions page 11 of manual.</p> <p>Return junction box for service.</p>
5. MORE ASSISTANCE	<p>Contact your local Farmscan Dealer or Computronics Corporation Ltd on +61 8 9470 1177. Fax: +61 8 9470 2855. Email: <a href="mailto:service@farmscan.net.au">service@farmscan.net.au</a></p>